



Metsec plc

Corporate Brochure

Metsec plc is the UK's largest specialist cold roll-forming company and a part of Voestalpine, the world's leading manufacturer of cold formed sections.



Metsec comprises eight product divisions, each one focused on its specialist market and customer base with equipment specifically designed to meet their needs.

Building Products

Purlin Division

Purlin and cladding rail systems for industrial and warehouse buildings.

Framing Division

Framing systems for infill walling, high bay separating walls and stand alone multi-storey buildings.

Lattice Division

Lightweight, long span lattice joists and beams.

Hepsec Division

Standard sections for partitioning, dry lining and ceiling systems all ex-stock.

Metstrut Division

Support systems for mechanical and electrical services.

Engineering Products

Custom Roll Forming Division

Open, closed, welded and pierced profiles in virtually any form and using a variety of material specifications.

Profile Manipulation Division

Bending, sweeping and general secondary processing of open and irregular shaped welded profiles.

Window Components Division

Steel reinforcement and ancillary profiles for the PVCu window, door and conservatory market.

Metsecplc

- **Adding value through expert design, precision manufacturing and fast delivery.**
- **Excellent service and quality products that offer our customers, cost effective solutions.**



Metsec designs and manufactures precision engineered cold rolled formed steel sections. These are either bespoke sections tailor-made to suit individual customer requirements, or lightweight structural systems for a wide range of applications in the building industry.

The company is both driven and differentiated by service, helping our customers maintain their competitive edge by designing the best solutions for each project and delivering high quality, added value products, in full and on time. We invest heavily in our plant and people. Alongside extensive new manufacturing facilities, wide-ranging workforce development programmes increase the skills of all our employees. We are also certified to ISO9000.

Established for over 75 years, Metsec plc is owned by the voestalpine group, one of Europe's leading specialist engineering companies. We are part of voestalpine's Profilform division, the world's largest manufacturer of cold roll-formed sections with a global network in the UK, Austria, Belgium, Czech Republic, Germany and the USA producing in excess of 700,000 tonnes per annum.



Metsec's service promise - quality, competitively designed construction components, delivered on time.



PurlinDivision

- **Technologically advanced rolling mills enable tighter tolerance sections.**
- **Market leading building shell design software and unrivalled technical support.**
- **Fast delivery to specific timescales.**



Metsec's Purlin division is the UK's largest designer and manufacturer of light gauge galvanised steel zed purlins and cladding rail systems for industrial and commercial developments. Manufactured from 390 N/mm² guaranteed yield strength material, our purlin systems have technical accreditation from the Steel Construction Institute.

Zed and C-sections in profile heights from 142mm to 342mm and thicknesses from 1.3mm to 3.2mm are available with a full range of accessories. Our customers are supported by market leading MetSPEC building shell design software with links to the latest wind code BS6399-2 and to the BREVe database for topography, plus access to dedicated technical helpdesks. Our ability to receive, process and programme our rolling mills directly from customers' using Electronic Design Data eliminates errors, improves efficiency and minimises delivery lead times.



Market leading structural framing systems, with full technical support from initial design to delivery.



FramingDivision

- **Unrivalled design and structural engineering expertise.**
- **Modern and flexible manufacturing facilities.**
- **Outstanding customer service with FrameSPEC software, technical support and quick delivery.**



Metsec's Framing division developed and now leads the market in light gauge, galvanised steel structural framing systems for commercial and residential buildings. Its two systems – Metframe, a pre-panelised wall system with concrete floors to provide complete superstructures and SFS, a site-fix system for infill walling – are both structurally proven, passing independent tests for thermal, acoustic and fire resistance performance. In line with modern methods of construction, Metframe is fabricated off-site and assembled by trained and approved installers to give fast, dry construction.

Unrivalled customer service includes taking full design responsibility from the customer at the outset, with our in-house team of skilled engineers producing detailed designs covered by professional indemnity insurance. Our manufacturing capacity and flexibility enables the fast and efficient supply of any size order of high quality, close tolerance, system components.



An extensive range of high strength, lightweight lattice joists, with free design and detailing.



LatticeDivision

- **Free design and detailing plus LatticeSPEC software.**
- **Extensive manufacturing facilities to meet any size order.**
- **Comprehensive product range with short delivery leadtimes.**



Metsec's Lattice division is the UK's largest manufacturer of lightweight steel lattice joists and trusses, including parallel, pitched, tapered and curved trusses and joists, with spans up to 34m. Lightweight and easy to handle, they offer ideal structural support with optimum strength to weight ratio. The open web configuration allows easy passage of services, whilst a timber insert flush to the top and bottom chords offers simple fixing of roof, floor and ceiling coverings.

All trusses and joists are detailed using the latest 3D modelling software and then downloaded directly to production where state of the art CNC machines automatically profile and punch component parts. This provides our clients with quality products in ever decreasing lead times.

Our extensive technical support includes a free design and detailing service, with layout and fixing detail drawings, plus full calculations for Building Regulations submission. Alternatively, free LatticeSPEC software, with links to the latest wind code, BS6399-2 and BREVe database for topography, helps architects and engineers carry out their conceptual designs quickly and easily.



Supplying high quality, lightweight metal sections for partitioning, dry lining and ceiling systems.



HepsecDivision

- **Supplied through major distributors.**
- **24 hour, ex-stock delivery.**
- **Full technical advice available.**



Metsec's Hepsec division specialises in supplying cold roll-formed metal framing systems for roofing, partitioning and building interior markets. The lightweight profiles are used to create metal furring systems, dry lining and suspended ceilings. As well as high volume manufacture of standard sections supplied ex-stock, Hepsec also offers a custom roll-forming service for bespoke sections.

As part of its customer service and technical support, Hepsec provides a free, stand-alone design program to make specifying Hepsec dry lining and suspended ceiling systems fast and easy.





An extensive range of cable management systems, with design support and on time delivery.

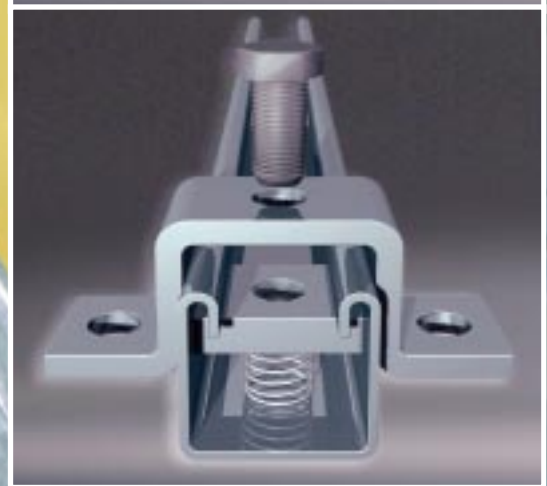
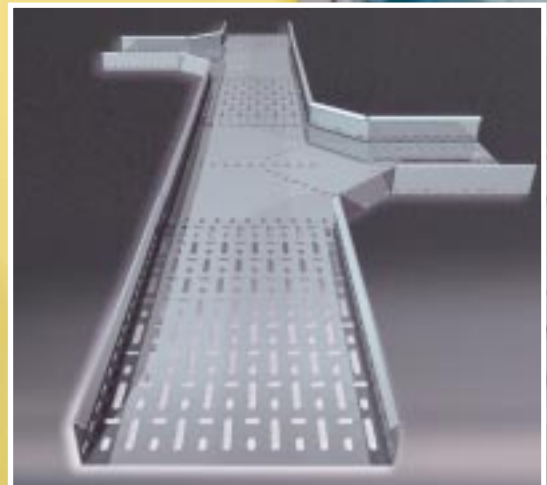
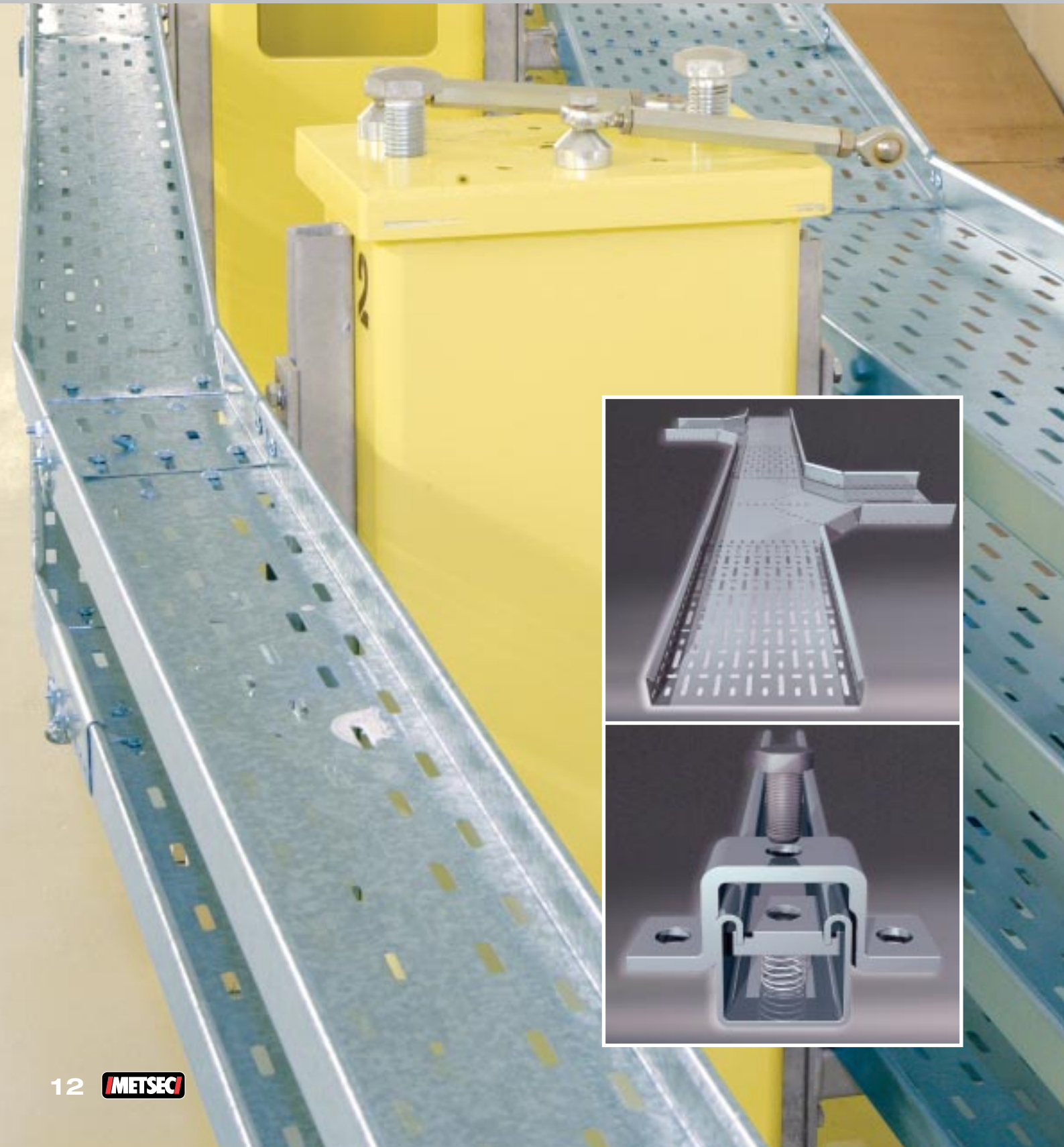

MetstrutDivision

- **Comprehensive product range, delivered on time.**
- **Added value prefabrication services available.**
- **DesignSPEC software for fast and easy design.**



Metstrut's extensive cable management portfolio provides a range of support systems for mechanical and electrical services. Products include cable ladder, cable tray and metal framing products, as well as a rapid installation range of channel and pre-assembled bracketry. All are designed as complete systems with simple accessories, offering flexible design solutions and easy installation. We can also offer a prefabrication service for major contracts, bringing significant time and cost savings for M&E contractors.

The technical customer support service includes free DesignSPEC software, a fast, accurate and easy method of designing cable management systems. DesignSPEC automatically calculates nominal loadings and selects the most efficient and cost effective Metstrut solution for that project. This ability to identify where lighter sections may be safely used can result in significant savings.





Specialist high quality engineered sections designed and manufactured to customer specifications.

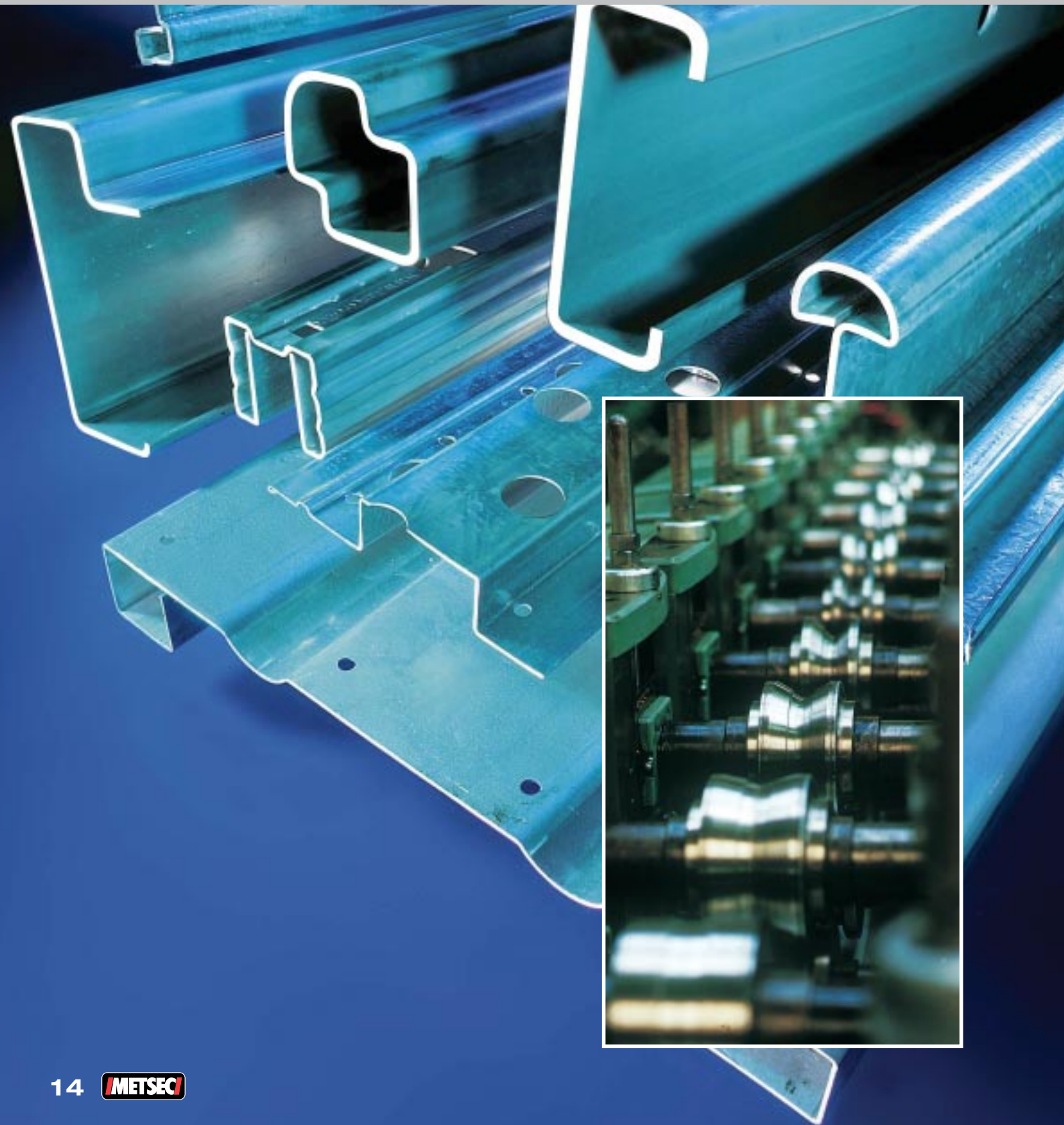

Custom Roll Forming Division

- **Partnership working to create and deliver well designed, precision engineered components.**
- **Extensive range of pre and post manufacture manipulation services offer added value.**
- **Broad technical capabilities offer a wide range of sections and materials.**



Custom Roll Forming is a leading specialist designer and cold roll-former of bespoke and standard metal profiles. We are capable of producing virtually any roll-formed section. Customers benefit from our extensive expertise in both profile design and material specification, receiving cost effective components in the shortest possible time.

CRF's dedicated Technology Centre and prototype engineering supports customers in developing the correct and most cost effective profile for their specific application. From there, we use specialist skills and equipment to manufacture the rolls and tools to produce the sections, guaranteeing consistent quality and repeatability, for use in a wide variety of industries such as racking, shelving, bridges and trailers.



Precision bending of metal components with added value manipulation services.



Optimum design, efficient manufacture and fast delivery of high quality steel reinforcing sections.



Window Components Division

- **Value engineered products.**
- **Technical support for optimum profile design.**
- **Shorter and more flexible delivery lead times.**
- **Stockholding.**



Metsec's Window Components division is one of the UK's leading specialist producers of steel reinforcing section for the PVCu window, door and conservatory market. Advanced manufacturing equipment ensures efficient production and enables us to deliver conventional and non-standard section, including cut to length profiles. Our large stockholding capacity enables shorter and more flexible lead times.

Supplying system companies and fabricators, we use our extensive technical expertise to value engineer products, reducing material content whilst still meeting high performance standards. Our in-house Technology Centre and prototype facilities are available to help customers design the optimum profile. In addition our MetPAD™ profile analysis design software helps engineers produce full details of system profiles.



Voestalpine KREMS GMBH

Schmidlüttenstrasse 5,
Postfach 43, A 3500 Krems
T. +43 (0) 2732 885-0
F. +43 (0) 2732 885-704
E. marketing.vak@voestalpine.com
www.voestalpine.com/profilform

SADEF

Bruggesteeweg 60, B-8830
Hooglede-Gits/Belgium
T. +32 (0) 51 261 211
F. +32 (0) 51 261 300
E. sales@sadef.be
www.sadef.be

Voestalpine**PRÄZISIONSPROFIL GMBH**

Franz-Tilgner-Strasse 10, D-50354
Hürth/Germany
T. +49 (0) 2233 6116-0
F. +49 (0) 2233 6116-16
E. info@praepro.de
www.voestalpine.com/
praezisionsprofil

RFC

P.O. BOX 369, Industrial Park,
Shelbyville, Kentucky
40066-0369/USA
T. +1 (502) 633 4435
F. +1 (502) 633 5824
E. sales@rfcorp.com
www.voestalpine.com/rfc

Voestalpine PROFILFORM s. r. o.

Továrni 4, CZ-68223
Vyskov/Czech Republic
T. +420 (0) 507 333 700
F. +420 (0) 507 333 702
E. marketing@vap-vyskov.cz
www.voestalpine.com/profilform-cz

**Metsec plc**

Broadwell Road, Oldbury,
West Midlands, B69 4HE.
T. +44 (0) 121 601 6000
F. +44 (0) 121 601 6119
E. metsecplc@metsec.com
www.metsec.com

voestalpine

ONE STEP AHEAD.